

High Concentration Ozone Analyzer



NEMA Wall Mount

Bench Top

Rack Mount

Ideal for monitoring ozone generator output

The **Model Mini-HiCon** is an innovative Ozone Analyzer that combines a state-of-the-art gas phase ozone sensing technology mounted in a rugged NEMA 4x wall mount enclosure most suitable for demanding industrial applications. It is ideal for measuring high concentrations of ozone gas produced by generators in a wide variety of applications up to 400 g/Nm³.

The Mini-Hicon analyzer incorporates IN USA's patented, no moving parts and innovative dual-optical path sample sensing technology to provide unparalleled performance and reliability.

In addition the analyzer provides powerful microprocessor-based control, display, and output capabilities. It includes an alphanumeric backlit LCD; 0-10 VDC and 4-20 ma opto-isolated analog outputs; bi-directional RS232 digital communications; remote autozero capability; and automatic compensation for sample pressure and temperature.

Applications:

- Ozone Generator Output
- Semiconductor tools
- Water treatment applications
- Ultrapure water
- Pilot studies
- Research projects

Industries:

- Semiconductor
- Wastewater Treatment
- Pharmaceutical
- Biotechnology
- Research Laboratories
- Other industrial processes

Features:

- UV Absorption technique
- Dual optical-path sample sensing
- No moving parts - minimal maintenance
- Pressure and temperature compensated
- Remote AutoZero

Specifications **Mini-HiCon**

ANALYZER:	Model Mini-HiCon™
Application:	Gas-phase ozone; continuous
Measuring Principle:	UV Absorption; dual optical-path sample sensing*
Pressure & Temperature:	Automatic compensation for sample pressure and temperature
UV Light Source:	Low pressure mercury vapor lamp
Units of Measure:	g/m ³ , g/Nm ³ , % w/w
Range:	0 to 400 g/m ³ , 0 to 26 % w/w (0-50, 0-100, 0-200 g/m ³ other ranges available)
Repeatability:	0.5 g/m ³ or 1% of reading, including zero drift; (higher precision available)
Resolution:	0.1 g/m ³ ; 0.01 % w/w
Cycle Time:	Continuous measurement; 0.5 sec or 2 Hz sampling rate
Sample Flow:	0.2 to 15 SLPM
Sample Ports:	1/4" Swagelok (others available)
Display:	20 character, alphanumeric, backlit LCD
Analog Outputs:	4 to 20 mA and 0 to 10 VDC, opto-isolated
Digital I/O:	RS-232-C, bi-directional
Diagnostics:	Internal diagnostics; instrument error relay
AutoZero:	Remote and Manual AutoZero Standard
Catalyst:	Mounted Externally
Power:	90 to 240 VAC 50/60 Hz
Dimensions:	NEMA 4x (17" W x 19.5" H x 9.6" D) Bench top (5.6" W x 2.8" H x 9.5" D)
Maintenance:	UV lamp replacement every 24 months. No other scheduled maintenance.
Compliance:	CE
	<i>Specifications subject to change without notice</i>

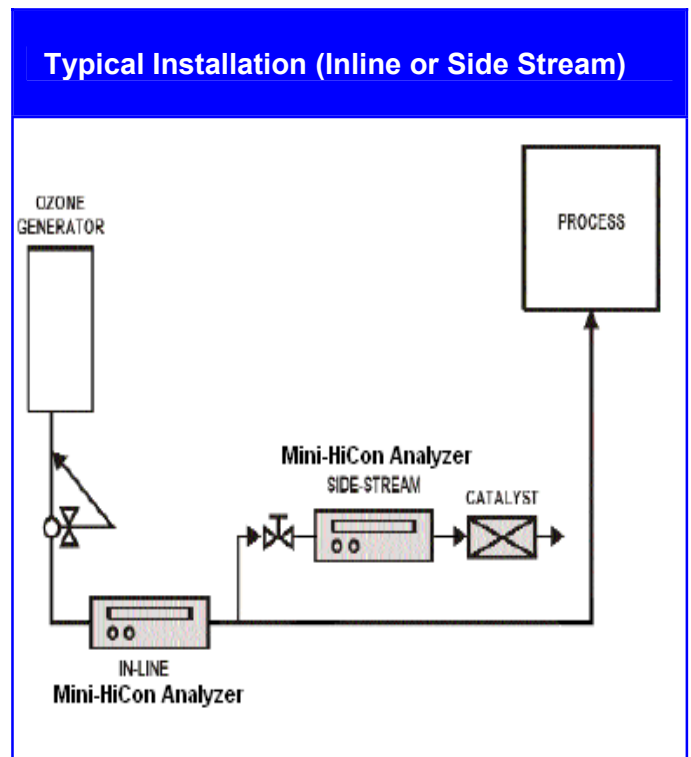

Ozone instrumentation for every application

	Generator Output	Safety/Leak Detection	Tool Leak Detection	Stack & Environmental	Dissolved Ozone	Spot Checking
Model dFFOZ					•	
Model gFFOZ	•					
Model Mini-HiCon	•					
Model L2RM			•	•		
Model IN-2000		•	•	•		
Model AET-030		•		•		•



Verrijn Stuartlaan 40
2288 EL Rijswijk
Tel 070 41 03 750
www.teesing.com